

★ **CLEAN ENERGY**
CRYOSTAR



low carbon technology for a cleaner world



www.cryostar.com

★ *Our mission*

To become a world leader of innovative solutions for financing by partnering, designing, installing & operating low carbon technologies in the power sector.

We will incorporate life cycle strategic partnering to achieve operational efficiency and economically effective programs



Low-Carbon, Low-Cost Energy



★ <i>Our mission</i>	P 2
★ <i>Cryostar - turbine experts for Lo-C energy generation</i>	P 2
★ <i>Energy recovery</i>	P 3
★ <i>Geo-pressure</i>	P 6
★ <i>Geothermal</i>	P 8
★ <i>Wasted heat (100°C-400°C)</i>	P 10
★ <i>Cryostar Lo-C energy technology options</i>	P 12
★ <i>Conventional bearing turbo generator</i>	P 12
★ <i>Magnetic bearing turbo generator</i>	P 13
★ <i>Services</i>	P 14





Cryostar - turbine experts for Lo-C energy generation

Cryostar has been a world leader in radial inflow turbine technology for more than 30 years and our superior product quality is recognised across the globe.

Since 1986, we have used our expertise to provide energy recovery solutions, ensuring optimum recovery through highly efficient and economical operations.

Our installed base comprises over 130 units and more than 60MW installed, including 20 machines on natural gas distribution networks. The natural gas installations have so far provided our customers with more than 1000 GWhs of recovered electricity.

Cryostar Lo-C has been established as a result of the rapidly increasing need for low carbon energy recovery and covers a variety of applications such as pressure let down, geothermal plants, waste heat and natural gas liquefaction.

The newly established Lo-C business unit within Cryostar focusing solely on low carbon technologies for energy recovery emphasises our long term strategic commitment to our customers in this area.

We have continuously built on our world class engineering skills and innovative drive to keep at the forefront of technological development in the industry. Our turbines are state-of-the-art technology that for decades have earned us world leader position in markets such as ship-board applications and air separation plants.

In addition to our technological expertise, Cryostar has a comprehensive service portfolio, which ensures complete peace of mind all through the purchase cycle—from product specification to long-term maintenance programmes.

Total electricity recovery from Cryostar install base in the World

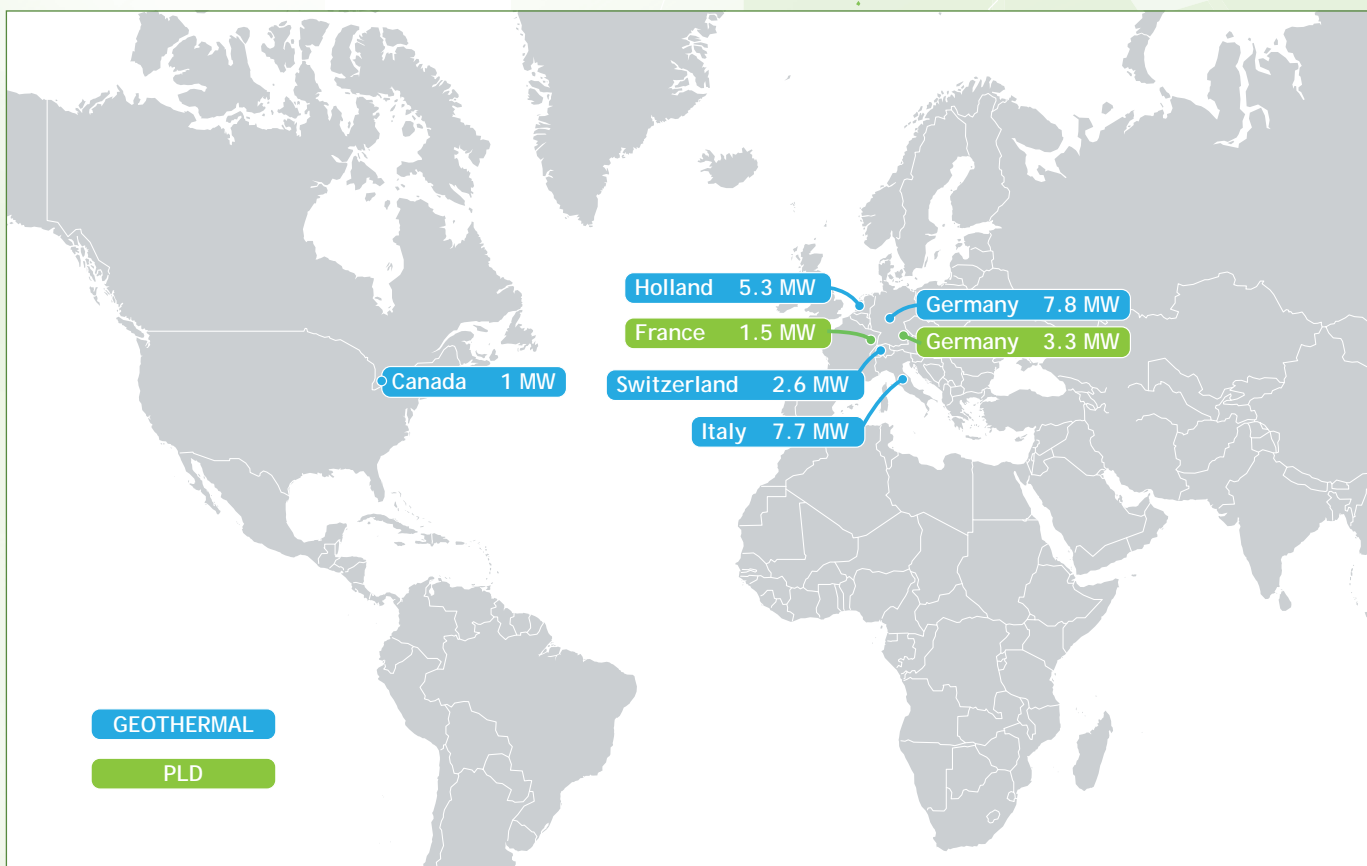

★ Energy recovery

As energy prices are continuously rising, the need for optimising energy usage and recovery is increasing rapidly. Governmental pressure on today's corporations to become environmentally friendly and reduce carbon emissions to the bare minimum is putting additional emphasis on the importance of energy recovery.

As the Cryostar technology merely recovers un-used energy this technology is CO2 emission free!

The principle of energy recovery is turning unharnessed energy into electricity. The expansion of a working fluid such as gas transfers kinetic energy into mechanical energy. Cryostar turboexpanders generate electricity by utilising the expansion process to rotate a wheel and generate electricity.



Here in Cryostar, over the last 20 years, we have been perfecting radial in-flow turbine to harvest wasted energy from a working fluid into electricity. This is by the direct conversion (primary cycle) of kinetic or mechanical energy into electricity, such as with our Geo-pressure units, the same principle by which wind power operates. The Geo-pressure units work in parallel with pressure reduction valves on gas networks.

Pressure reducing valves = Cryostar Lo-C Energy electricity generation

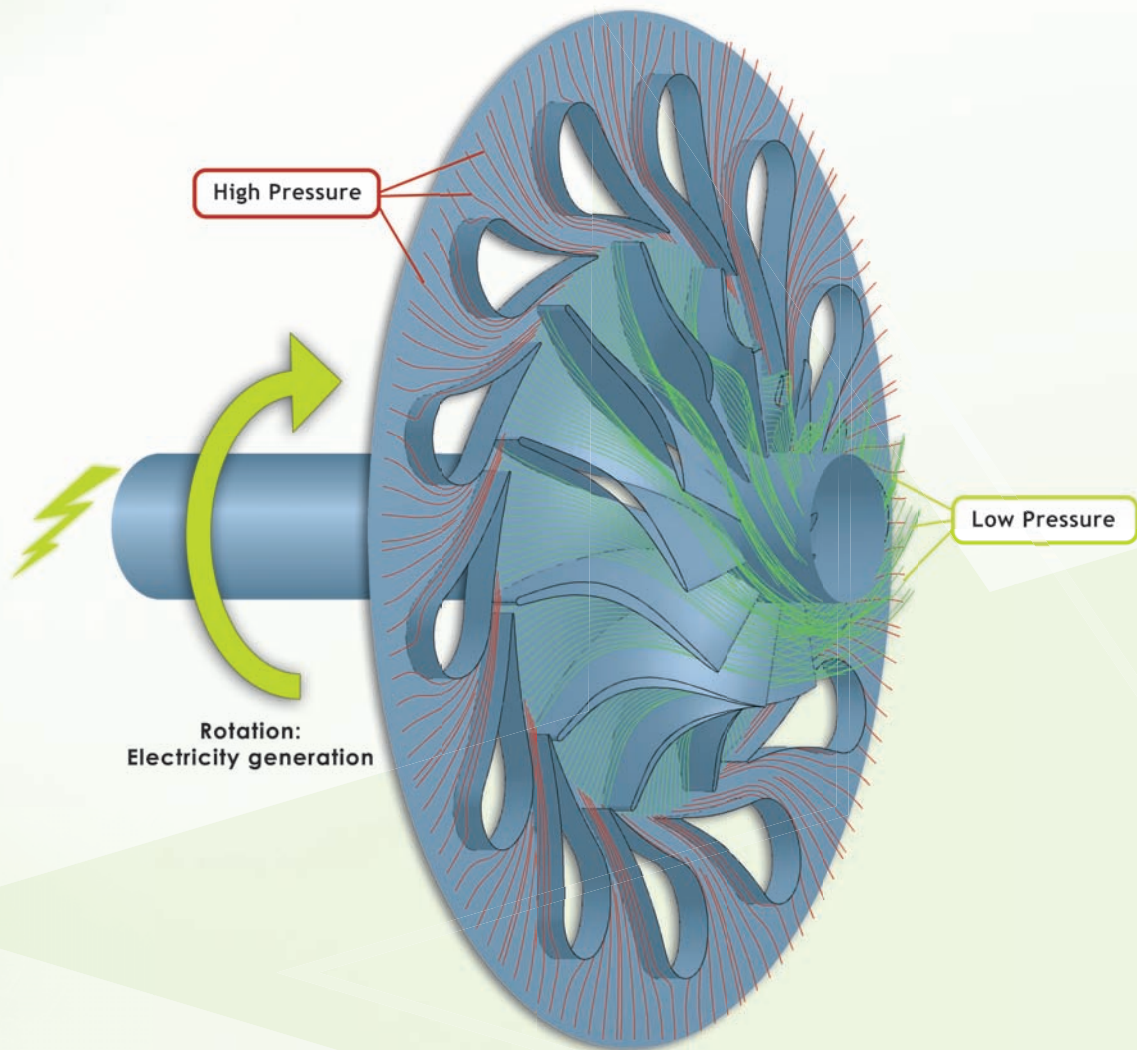

The second method (binary cycle) is by converting low grade heat (100° C+) into a working fluid, then expanding it through the radial in-flow turbine which converts the kinetic energy into electricity, the principle used for geothermal and wasted heat electricity plants.

Geothermal or waste heat = Cryostar Lo-C Energy electricity generation

★ Geo-pressure

Natural gas comes out of the ground at a very high pressure, called Geo-pressure. It is this pressure that moves the gas through the pipelines of the gas distribution system. However, the pressure is too high to be used safely by end-users of gas (power stations, industrial, commercial and domestic users).

The pressure at the production platform is between 100-800 bar. In order for the gas to be suitable for domestic use it will have to be available at 1 bar (the pressure of the gas used by a cooker for example).

At several points in the system, therefore, gas goes through 'pressure reduction stations', where the pressure of the gas is reduced by squeezing it through a valve. Reducing the pressure in this way releases energy. In most instances this energy is presently not being harnessed though it is possible to generate carbon free electricity, merely by installing a turbine generation system at some of these stations.

The gas passes through this turbine as the Geo-pressure is reduced, and the turbine generates electricity. No gas is burned or used up in this process. It is similar to hydro-power, it is the flow of the water that turns the turbine or mill, but the water itself is unchanged by the process.

As it is not the gas but the actual pressure reduction which produces energy, Geo-pressure also applies to other fluids where pressure is reduced such as for example with geo-steam.

*Geo-pressure is a travelling companion of natural gas
Geo-pressure follows the electrical base load demand*

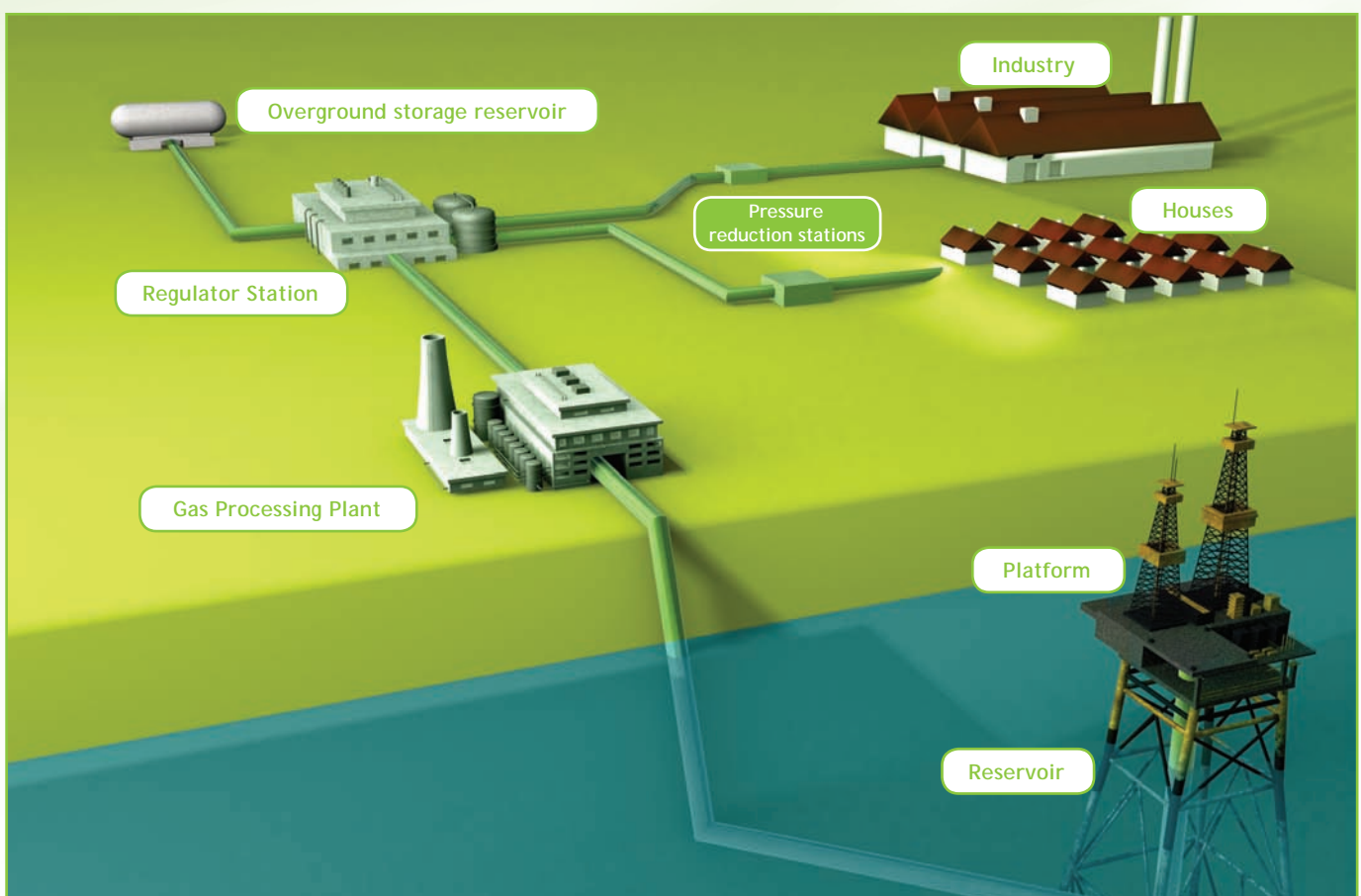

★ Geo-pressure

The amount of electricity that can be generated from a pressure reduction station depends on the required pressure drop and flow.

Cryostar designs and builds turbines to customer requirements in the Geo-pressure industry. Our radial inflow turbines are suitable for this application as these have high reliability and an efficiency up to 92% ensuring that optimal energy recovery is achieved.

Use the Cryostar Geo-pressure calculator to estimate the level of potential electricity generation.

With all the thought and effort that has gone into the conception of this first unique power station in Switzerland, we believe that all Cryostar's objectives for reliability and service have been met. Especially to reach a 10 % higher power efficiency than guaranteed in the contract.

Mr. Kreyenbühl, GVM

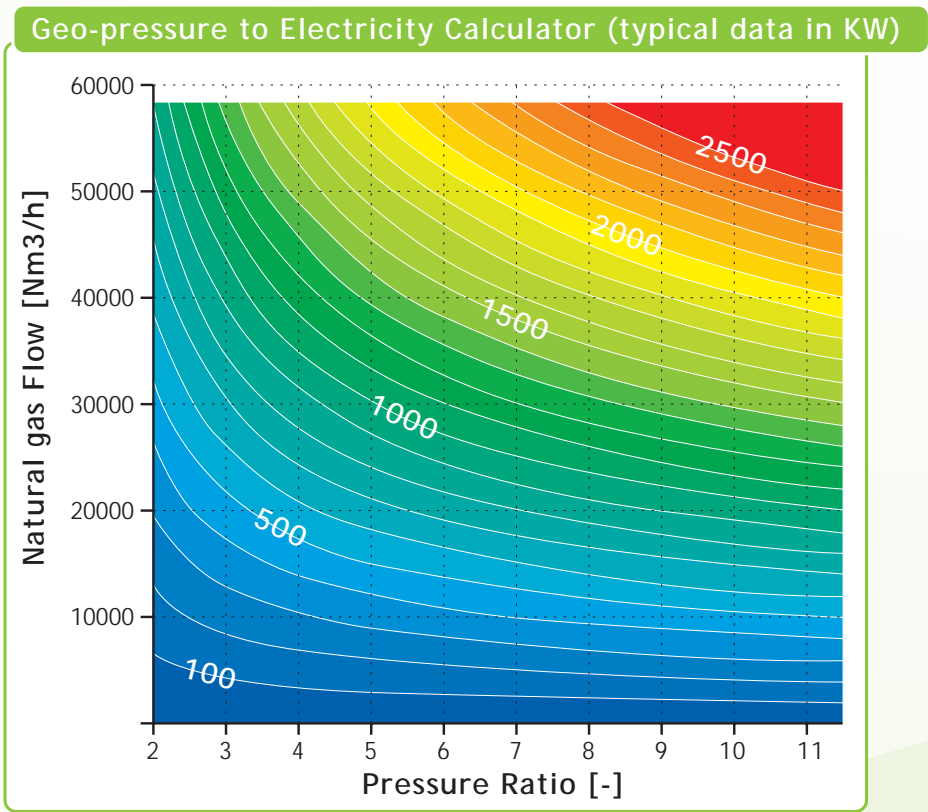

In the Geo-pressure energy recovery unit in Arlesheim (GVM) commissioned by Cryostar in 2003, to reduce the natural gas pipeline pressure of 55 bar to meet the low pressure of the local gas distribution networks, a pressure drop is needed. In other words, the gas flow from 35,000 Nm³/h is allowed to expand and during this process drives the Cryostar turbines within the Geo-pressure energy recovery unit.

The turbine wheel drives a gearbox coupled to a synchronous generator. The resulting 1,9MW of electricity recovered in this way is then supplied to local electricity suppliers. The electrical efficiency of the whole installation is about 85%*, vastly superior value when compared to CHPs, gas and steam turbines and even fuel cell.

* "Stromerzeugung mit Erdgas-Entspannungsanlage" issued from German Magazin GWA 6/2004

★ Geothermal

Imagine the huge energy potential which stays unexploited under our feet: only 0.1% of our globe is colder than 100°C.

One Km³ of 200°C hot granite cooled by 20°C delivers about 10 MW of electric power for a period of 20 years.

One km³ of 180°C hot geothermal water cooled to 100°C delivers about 7 MW of electric power for a period of 250 years

Put in another way; installed 1 MW is enough to supply 2500 homes every year.

Geothermal water has been used since the Roman time principally for bathing, but nowadays it is also a way to produce electricity even for low temperature sources of about 100°C.

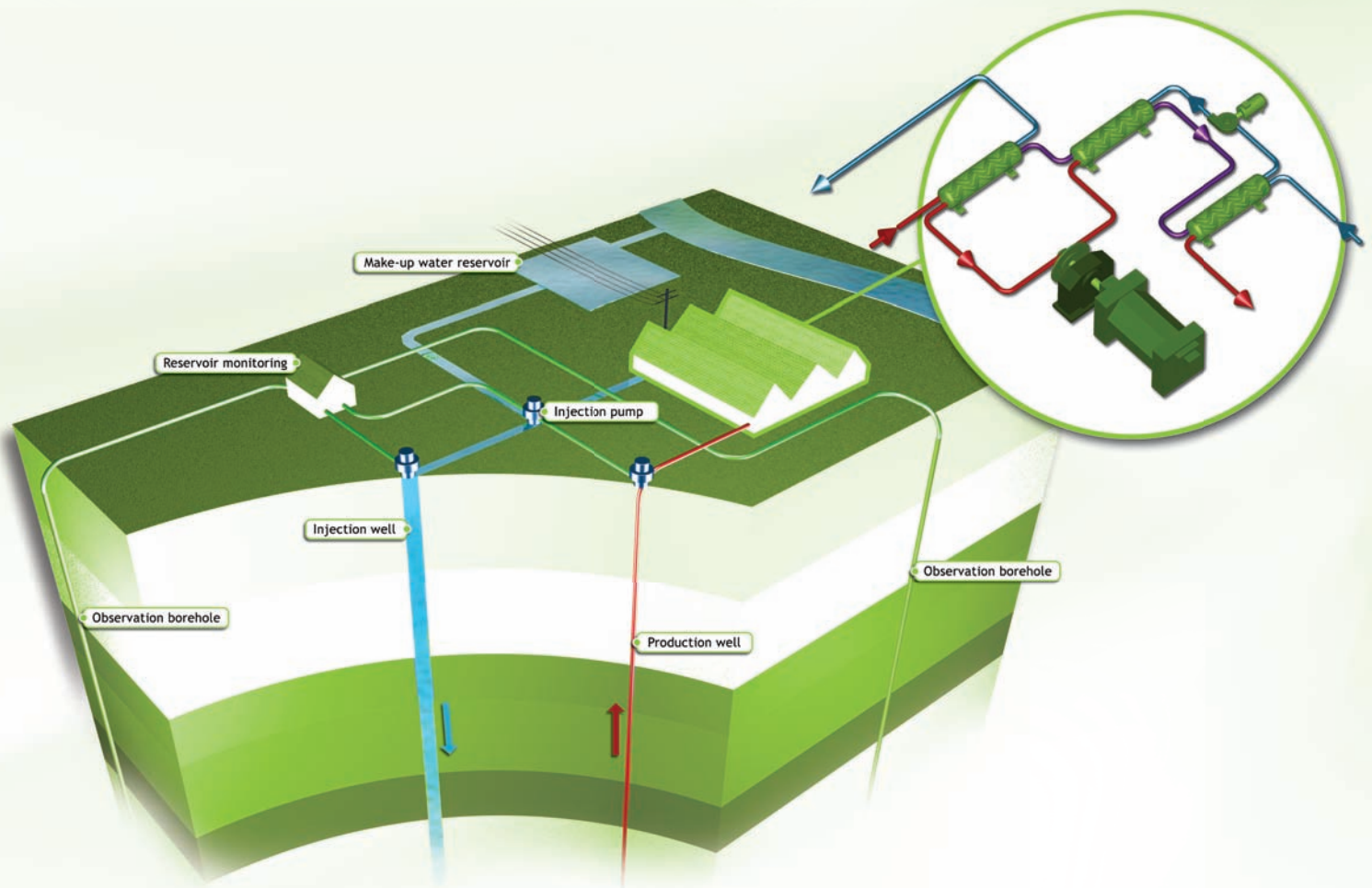

Hot water coming from an aquifer source is pumped up. This natural source of heat is used to vaporise an appropriate working fluid mixture with a boiling point below 100°C. The vapour is then expanded through a radial inflow turbine which drives a generator and delivers electricity to the grid. The low pressure vapour is then condensed with an existing cold source (fresh water or ambient air) and the liquid is pumped back to the evaporator to begin the cycle again.

The hot geothermal water which was cooled by the cycle can be used for district heating and then returned to depth.

The Cryostar technology of high efficient radial inflow turbine perfectly matches the needs of this application. Unlike axial turbines, the efficiency of Cryostar’s expander can reach 90% or more ! Thanks to in-house developed tools, Cryostar engineers have the ability to optimise the process (mainly working fluid and pressure level) and the expander to offer to the customer the optimum choice taking recovered power and cost into consideration.

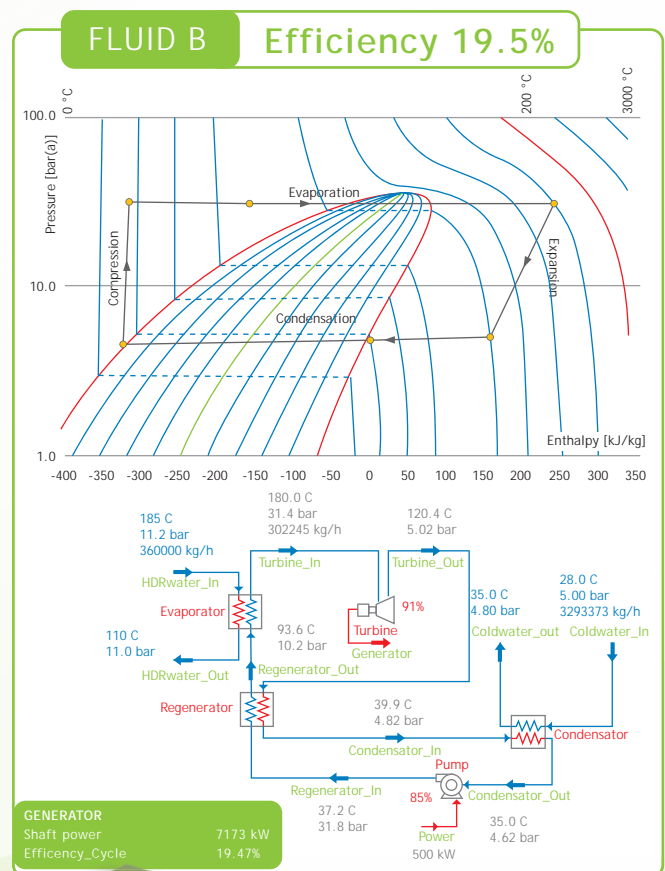
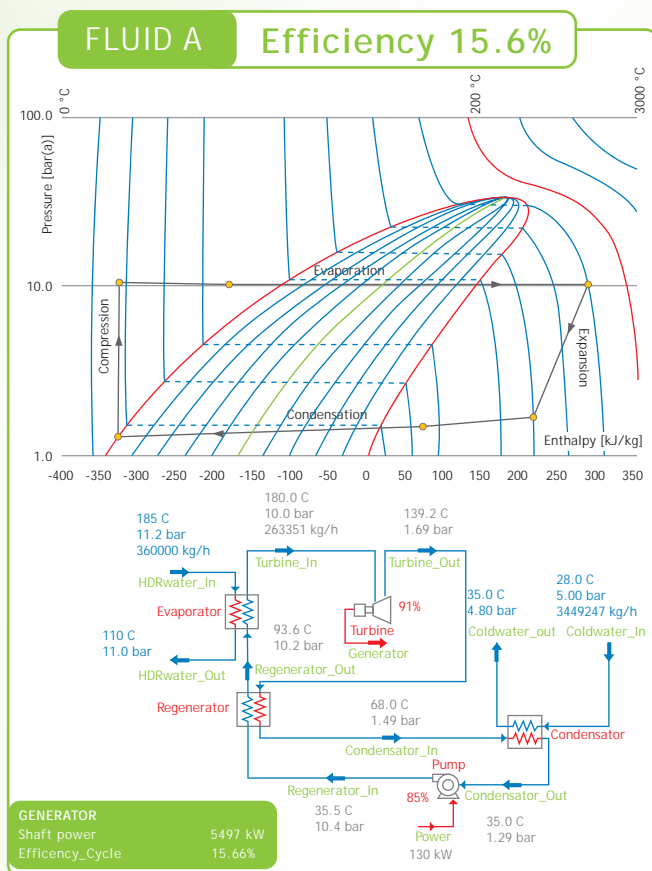

Application in Action

Cryostar is working with a German customer in order to provide a tailored turbine solution for a Geothermal application. The objective is to produce electricity from geothermal heat, with 100 l/s of geothermal fluid at 180°C. Operating a closed loop binary cycle, the appropriate fluid mixture is expanded inside the Cryostar turbine to produce 6 to 7 MW of clean electricity without any CO2 emission. The remaining low grade temperature is able to supply a local district heating network.

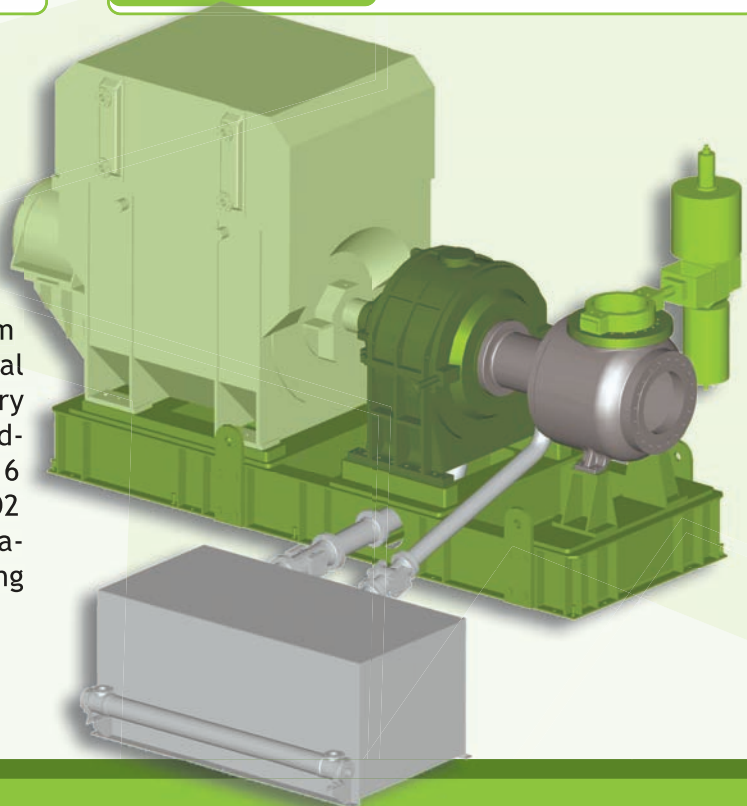



Wasted heat (100°C-400°C)

A waste heat binary plant is quite similar to a geothermal binary plant, hence the thermal energy is coming from an unexploited heat source (100°C–400°C typically) for example a thermal oil loop in an industrial plant, steel factory, cement factory, glass manufacturer etc. Thanks to a closed loop binary cycle, the selected fluid mixture is expanded inside the Cryostar turbine to produce 1 to 12 MW of clean electricity.

In order to estimate potential electricity recovery the following rule of thumb can be applied:

$$\text{Electrical Power[kW]} = 0.5 \times \text{Thermal WasteHeat[kW]} \times \left[1 - \frac{\text{Cold Source Temperature[°K]}}{\text{Hot Source Temperature[°K]}} \right]$$

How much electricity could be recovered from 5000 kW waste heat ?

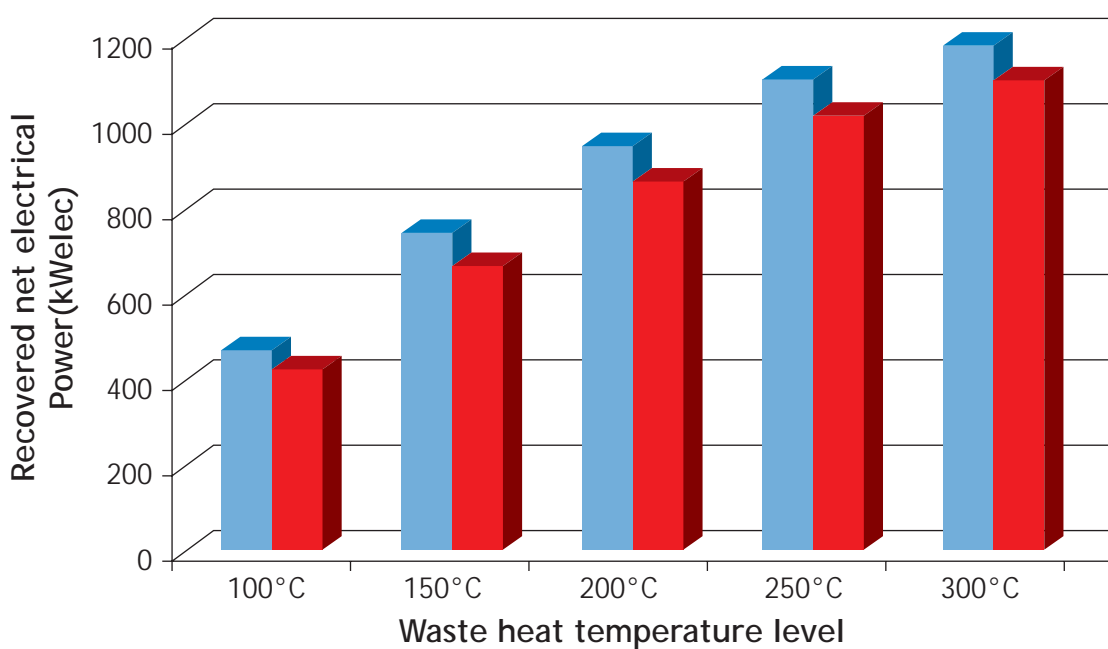

■ Cold source: 35°C ■ Cold source: 45°C

Potential sources:
Biomass Boilers
Biogas Engines
Residual Heat from Industries
Solar Heat
Fuel Exhaust Heat

In a typical Organic Ranking Cycle (ORC) heat recovery system, the exhaust gas enters the evaporator where heat is transferred to the ORC working fluid in a shell & tube heat exchanger or through an intermediate loop with thermal oil. The working fluid leaves the evaporator as superheated vapor and enters the expander which starts rotating. Electricity is then produced by the expander's shaft coupled to a generator. When the fluid leaves the expander, its waste heat is recovered in the regenerator by pre-heating the incoming liquid. The ORC working fluid then enters the condenser. The resulting saturated liquid is pumped back and preheated in the recuperator before entering the evaporator again.

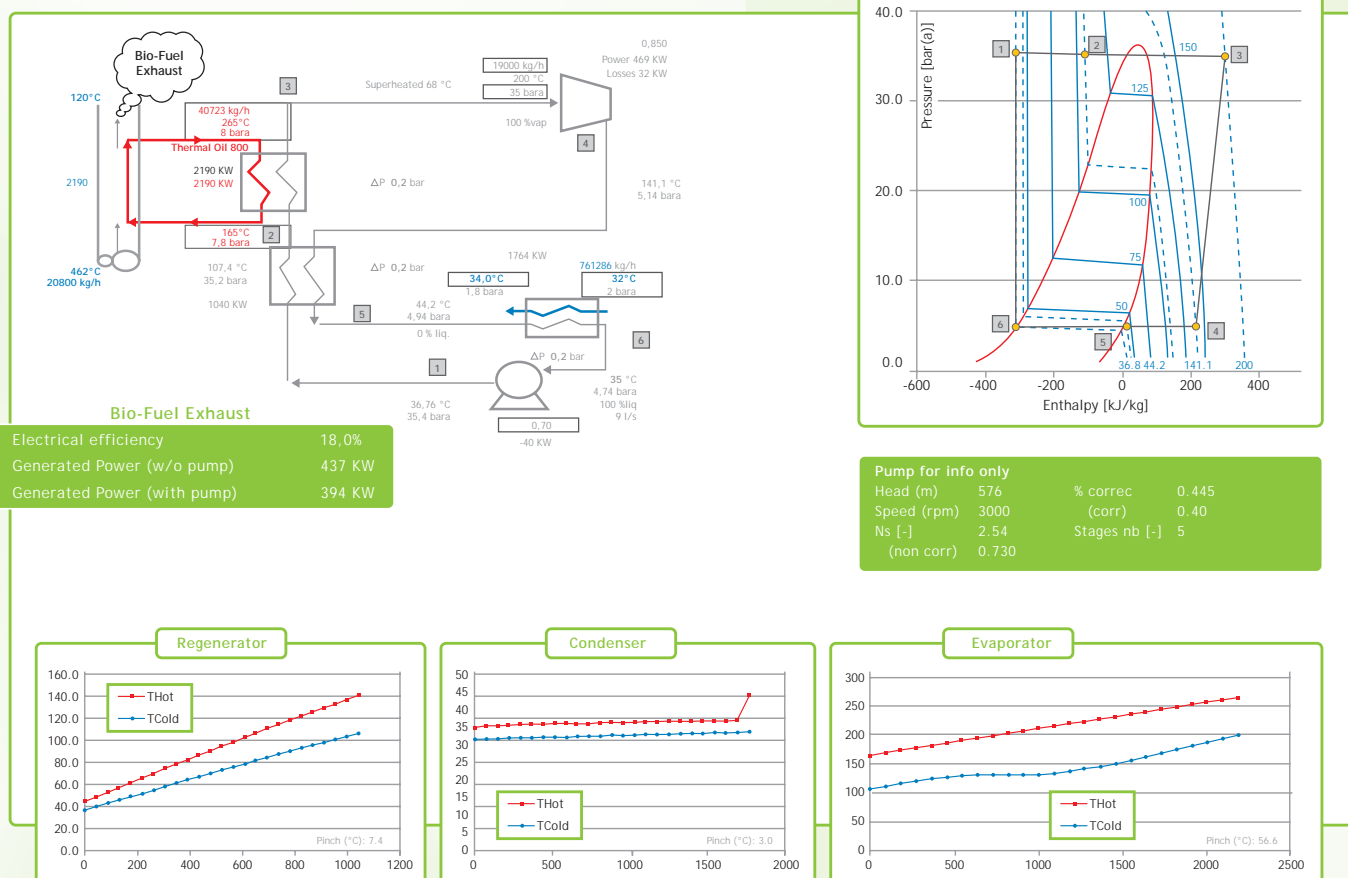



Cryostar Lo-C energy technology options

Having had a world-leading position in the turbo-expander market for more than 20 years, Cryostar is able to offer customers unrivalled state-of-the-art technology.

Cryostar's highly qualified engineers ensure that all customer requirements are met through innovative solutions and that investment pay back is guaranteed.

Our product range includes both Cryostar radial inflow turbo-expander packages with or without magnetic bearings supplied by one of its sister companies.



Conventional bearing turbo generator

This turbo generator is fitted with unique propriety thrust bearing design. The package is skid mounted in order to have optimum and stable alignment of the turbine, high speed reducer and synchronous/asynchronous generator. Impellers are designed according to the needs of the process, out of a family of impellers that have been designed with the most modern computing tools for best efficiency and mechanical behaviour. The oldest units in operation are still running perfectly with a minimum of maintenance.

Turbo Generator benefits:

- low capital cost versus power production;
- high efficiency in medium to high flow application;
- dual stage expansion turbine with a single generator available;
- specific seal gas solution avoiding any costly inert gas generator.

★ *Magnetic bearing turbo generator generator*

The magnetic turbo generator is made of a turbine wheel driving a high speed generator mounted on two magnetic bearings. The bearings keep the rotor in levitation thanks to electromagnetics flux generated by stator windings. The resulting electricity at high frequency is then converted into regular grid voltage through an inverter.

Magnetic Turbo Generator benefits:

- small footprint;
- non contacting bearing technology eliminating bearing wear;
- low operating costs (oil free design);
- low mechanical losses allowing higher efficiency



★ Services

Given the critical nature of its products for energy recovery and subsequent cost savings, Cryostar is well aware of the importance of our service. Consequently, Cryostar's role goes beyond the delivery of the turbines to finding solutions and bringing added value to our customers.

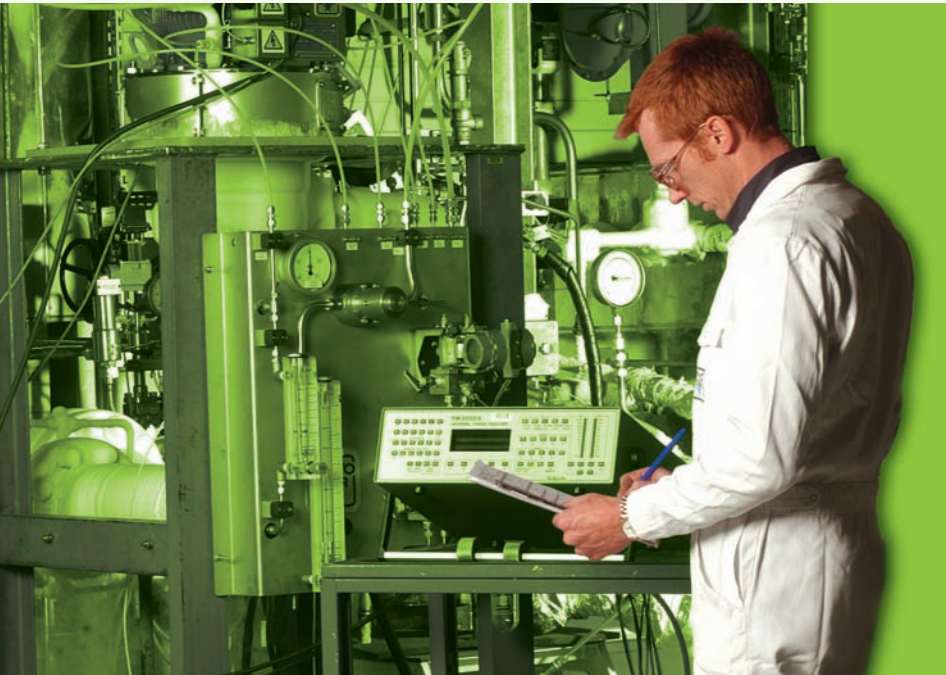

Our pre-sales and after sales service is second to none, which means customers receive expert advice through the whole design and purchase cycle as well as possibilities of long term maintenance contracts once the turbine is up and running to guarantee investment.

The Cryostar headquarter in Hesingue, France hosts the worlds biggest and most sophisticated pump and turbine testing facility. Here we pre-test all turbines leaving our site, ensuring that only products that have passed our stringent test requirements are shipped to the customer.

Cryostar's worldwide presence through eight business centres and 13 agents, enables us to provide customers with a high level of service and short response times.







Expert in advanced technologies for Industrial Gas,
Clean Energy, LNG and Hydrocarbon applications



★ CRYOSTAR SAS

ZI - BP 48
68220 Héringue
France
info@cryostar.com

Phone: +33 (0)3 89 70 27 27
Fax: +33 (0)3 89 70 27 77

★ CRYOSTAR Automation

Saint Julien d'Empare
12700 Capdenac
France
info@cryostar.com

Phone: +33 (0)5 65 80 20 20
Fax: +33 (0)5 65 80 20 25

★ CRYOSTAR Brazil

Av. Santo Amaro, 2820-Brooklin
São Paulo - SP
CEP 04555-000
Brasil
brazil@cryostar.com

Phone: +55 11 8697 1054

★ CRYOSTAR China

Third building
No. 17 Shanxian Road,
Hangzhou - China 310004
china@cryostar.com

Phone: +86 571 8536 8331
Fax: +86 571 8536 8409

★ CRYOSTAR Singapore

203 Henderson Road
BLK B#10-09
Henderson Industrial park
S(159546) - Singapore
singapore@cryostar.com

Phone: +65 6276 7441
Fax: +65 6276 7442

★ CRYOSTAR UK

Kea Park Close
Hellaby, Rotherham
South Yorkshire S66 8LB - UK
uk@cryostar.com

Phone: +44 1709 702 777
Fax: +44 1709 702 771

★ CRYOSTAR USA East

5897 Colony Drive
Bethlehem
PA 18017 USA
usa@cryostar.com

Phone: +1 (484) 281-3401
Phone: 1-800-483-1052 (for US and Canada only)
Fax: +1 (484) 281-3402

★ CRYOSTAR USA West

13117 Meyer Road
Santa Fe Springs
CA 90670
usa@cryostar.com

Phone: +1 (562) 903-1290
Phone: 1-800-483-1052 (for US and Canada only)
Fax: +1 (562) 903-4511

★ Cryostar USA - Houston Office

5909 West Loop South,
Suite 220
Bellaire, TX 77401

Phone: +1 (713) 661-6000
Fax: +1 (713) 661-6075